

Stair Stringer Tables for Trus Joist® 1 1/2" 1.3E TimberStrand® LSL and 1 3/4" 1.55E TimberStrand® LSL

The information presented in this technical bulletin is intended to assist with the specification of stair stringers that utilize 1 1/2" 1.3E TimberStrand® LSL or 1 3/4" 1.55E TimberStrand® LSL. For additional design and installation guidance, please reference *Stair Stringers and Treads Specifier's Guide*, Reorder [9010](#).

MAXIMUM STRINGER RUN – 40 PSF (LIVE) \ 12 PSF (DEAD)

Material	Depth	36" Tread Width				42" Tread Width		44" Tread Width		48" Tread Width	
		2 Stringers		3 Stringers		3 Stringers		3 Stringers		3 Stringers	
		Without Reinforcement	With 2x4 Reinforcement	Without Reinforcement	With 2x4 Reinforcement	Without Reinforcement	With 2x4 Reinforcement	Without Reinforcement	With 2x4 Reinforcement	Without Reinforcement	With 2x4 Reinforcement
1 1/2" 1.3E TimberStrand® LSL	9 1/2"	5'-10"	6'-8"	6'-8"	7'-6"	5'-10"	7'-6"	5'-10"	7'-6"	5'-10"	6'-8"
	11 7/8"	9'-2"	10'-0"	10'-10"	11'-8"	10'-0"	10'-10"	10'-0"	10'-10"	9'-2"	10'-10"
	14"	12'-6"	12'-6"	14'-2"	14'-2"	13'-4"	13'-4"	13'-4"	13'-4"	12'-6"	12'-6"
1 3/4" 1.55E TimberStrand® LSL	9 1/2"	5'-10"	7'-6"	7'-6"	8'-4"	6'-8"	7'-6"	6'-8"	7'-6"	6'-8"	7'-6"
	11 7/8"	10'-0"	10'-10"	11'-8"	12'-6"	10'-10"	11'-8"	10'-10"	11'-8"	10'-10"	11'-8"
	14"	14'-2"	14'-2"	14'-2"	14'-2"	14'-2"	14'-2"	14'-2"	14'-2"	14'-2"	14'-2"

See **General Notes** on page 3.

MAXIMUM STRINGER RUN – 100 PSF (LIVE) \ 12 PSF (DEAD)

Material	Depth	36" Tread Width				42" Tread Width		44" Tread Width		48" Tread Width	
		2 Stringers		3 Stringers		3 Stringers		3 Stringers		3 Stringers	
		Without Reinforcement	With 2x4 Reinforcement	Without Reinforcement	With 2x4 Reinforcement	Without Reinforcement	With 2x4 Reinforcement	Without Reinforcement	With 2x4 Reinforcement	Without Reinforcement	With 2x4 Reinforcement
1 1/2" 1.3E TimberStrand® LSL	9 1/2"	4'-2"	4'-2"	5'-0"	5'-10"	4'-2"	5'-0"	4'-2"	5'-0"	4'-2"	5'-0"
	11 7/8"	6'-8"	7'-6"	7'-6"	8'-4"	7'-6"	8'-4"	7'-6"	8'-4"	6'-8"	7'-6"
	14"	9'-2"	9'-2"	10'-0"	10'-0"	10'-0"	10'-0"	10'-0"	10'-0"	9'-2"	9'-2"
1 3/4" 1.55E TimberStrand® LSL	9 1/2"	4'-2"	5'-0"	5'-0"	5'-10"	5'-0"	5'-10"	5'-0"	5'-10"	5'-0"	5'-0"
	11 7/8"	7'-6"	8'-4"	8'-4"	9'-2"	8'-4"	9'-2"	8'-4"	8'-4"	7'-6"	8'-4"
	14"	10'-0"	10'-0"	11'-8"	11'-8"	10'-10"	10'-10"	10'-10"	10'-10"	10'-10"	10'-10"

See **General Notes** on page 3.

Connection Requirements

High End Connection

- 40 PSF (live) \ 12 PSF (dead) & 100 PSF (live) \ 12 PSF (dead)
 - Two A35 framing anchor clips by Simpson Strong-Tie® fastened with twelve 8d (0.131" x 1 1/2") nails OR
 - Two MPA1 framing anchors by USP® fastened with twelve 8d (0.131" x 1 1/2") nails

High End

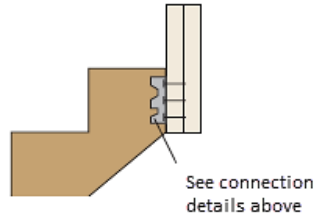

Low End Let in Connection

- 40 PSF (live) \ 12 PSF (dead)
 - Eleven 10d (0.148" x 3") nails into framing member below OR
 - Six 3" long (1/2" diameter) bolts into concrete
- 100 PSF (live) \ 12 PSF (dead)
 - Seventeen 10d (0.148" x 3") nails into framing member below OR
 - Six 3" long (1/2" diameter) bolts into concrete

Low End

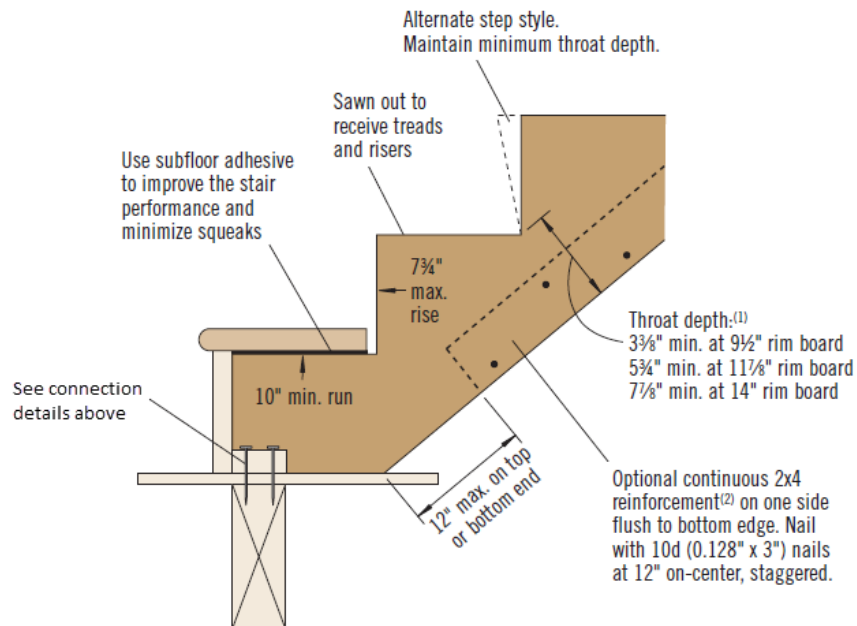

(1) Minimum throat depths may be reduced by an additional 1/4" for 11 7/8" and 14" material depths if 2x4 reinforcement is used and provided total rises and runs are limited to table values for unreinforced stringers.
 (2) Minimum No. 2 hem-fir, spruce-pine-fir or better grade.

General Notes

- Maximum stringer runs shown are valid for U.S. codes (Allowable Stress Design) or Canadian codes (Limit States Design). Loads shown are unfactored.
- Deflection criteria of L/360 live load and L/240 total load.
- Stairway assembly is unstable until treads are installed.
- Use subfloor adhesive to improve stair performance and minimize squeaks. See adhesive recommendations on page 4 of Reorder [9010](#).
- Tables based on 7 3/4" maximum rise and 10" minimum run. Local codes may be more restrictive.
- Maximum rise between floors or landings permitted by code is 12'-0".
- Keep materials dry. Add a vapor barrier at the bottom of the stair stringer if it is in contact with concrete.

General Guidelines for Calculating Step Rise and Run

- The product of the rise and the run should equal approximately 75".
- Two times the rise plus one run should equal approximately 25".
- Rise plus run should be 17" to 18".

